

VXX-12 HIGH VAC SMALL PUMP

AIR CONSUMPTION : 72 lit per min at 6 BAR.

WORKING PRESSURE : 5-6 BAR.

MAX SUPPLY PRESSURE : 7 BAR.

MAX VACUUM : -0.93 ATM at 5.5 BAR.

MAX VACUUM FLOW : 152 lit per min.

WORKING TEMP. : -20°C + 100°C.

WEIGHT : 110 g.

NOISE LEVEL : 65 db(A) full flow,
60 db(A) full vacuum.

MATERIALS : Epoxy painted AL, brass,
silicon rub, neoprene, stainless steel.

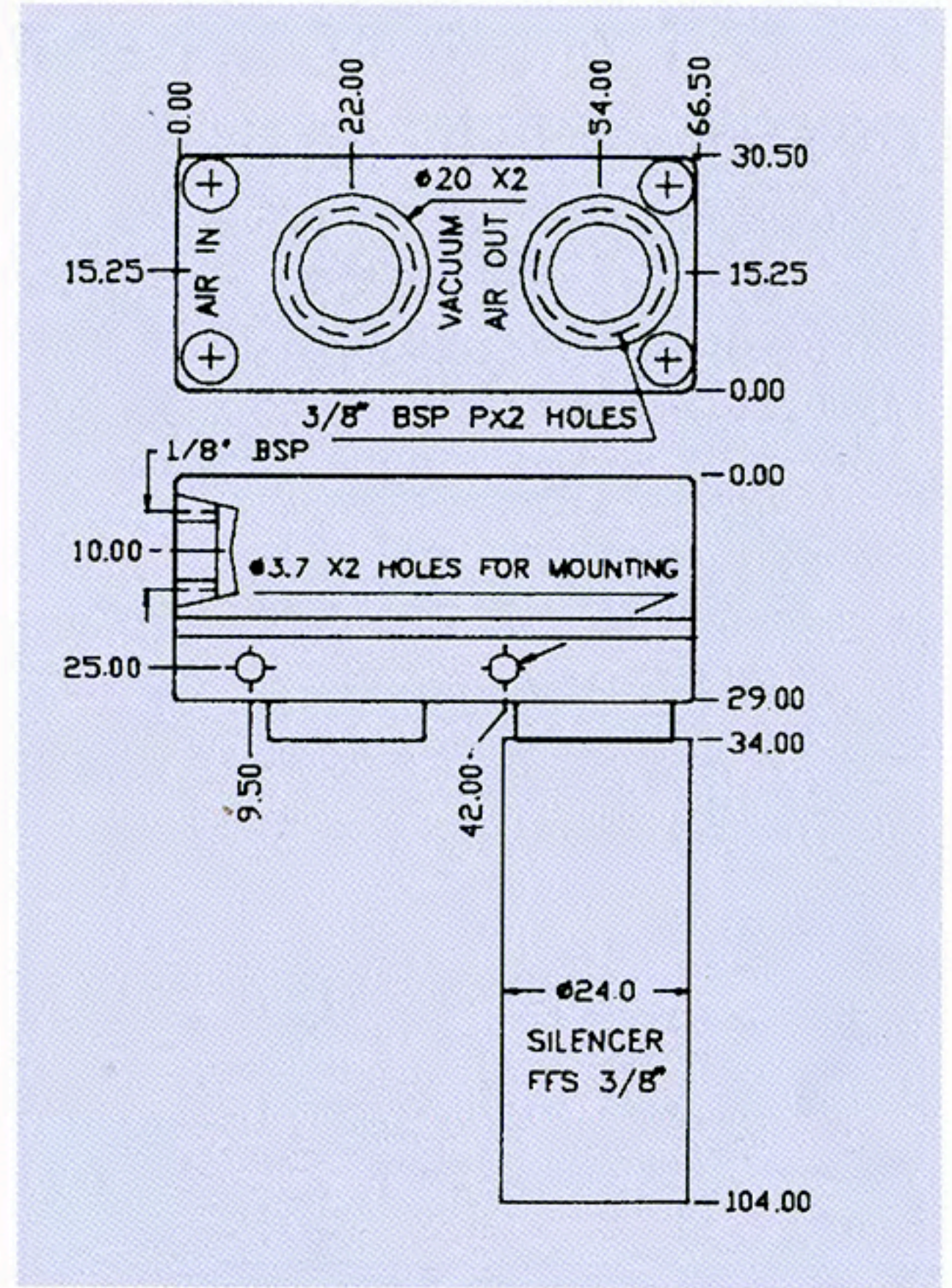

NOTE:

VXX Pumps are often used for handling materials or clamping small parts. They can be used with several suction cups. Try to minimize the distance between pump and cup.

vacuum in - ATM	0.1	0.2	0.3	0.4	0.5	0.6	0.7	0.8	0.9
time in sec for evacuation of 1 lit to vac' level	0.075	0.14	0.23	0.33	0.48	0.63	0.85	1.15	2.32

vacuum in - ATM	0	0.1	0.2	0.3	0.4	0.5	0.6	0.7	0.8	0.9
induced air in lit per min.	152	104	86	81	72	57	48	28	19	9.6

