

## VLP-48 LOW VACUUM PUMP

**AIR CONSUMPTION** :950 lit per min at 6 BAR.

**WORKING PRESSURE** : 4-6 BAR.

**MAX SUPPLY PRESSURE** : 7 BAR.

**MAX VACUUM** : -0.7 BAR at 6 BAR.

**MAX VACUUM FLOW** : 3200 lit per min.

**WORKING TEMP.** : -20°C + 80°C.

**WEIGHT** : 3200 g.

**NOISE LEVEL** : 72 db(A) full vacuum.

**MATERIALS** : Epoxy painted AL, brass, neoprene, stainless steel.

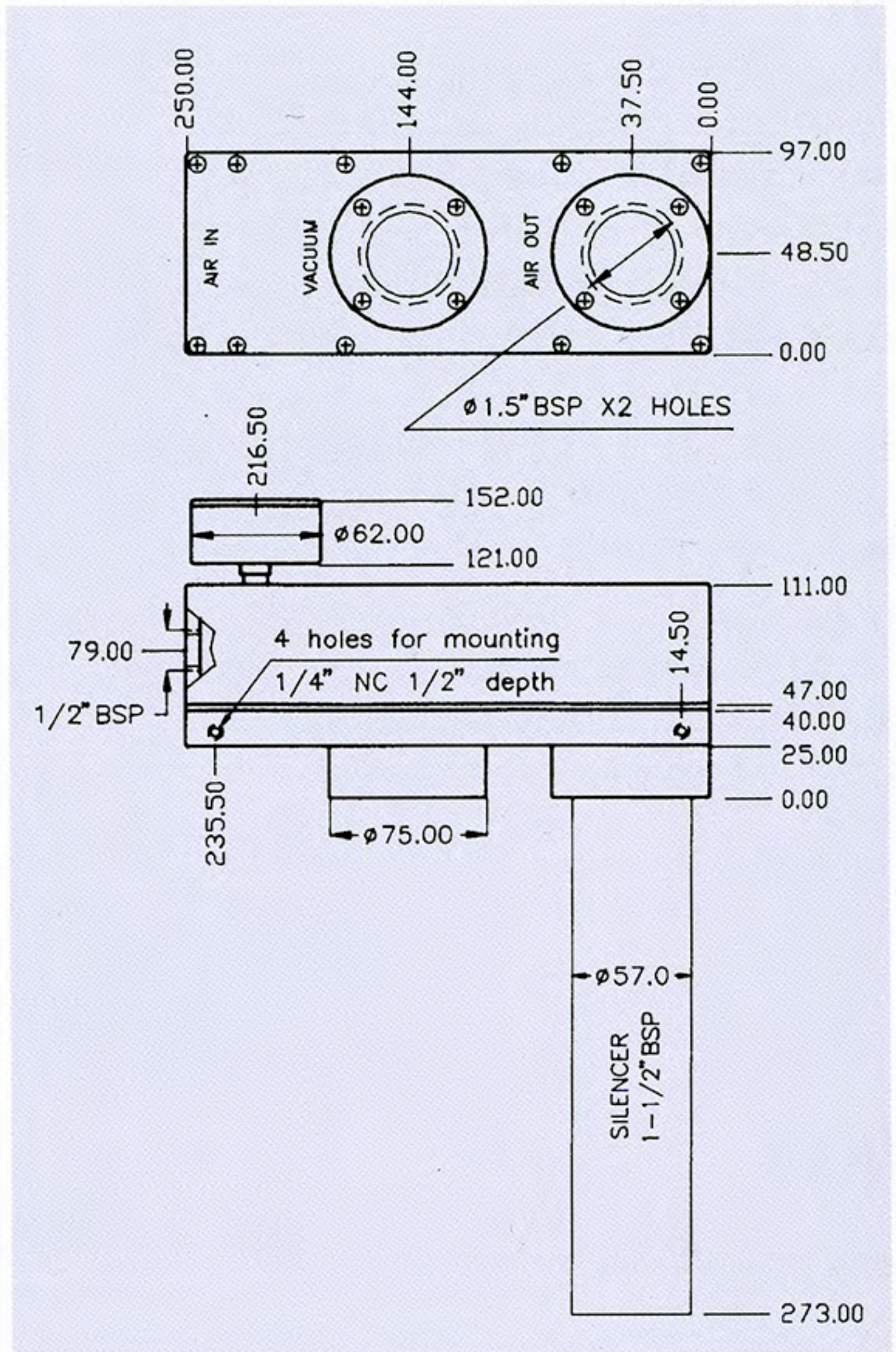

### NOTE:

VLP Pumps are often used for high flow vacuum needs in porous materials, cartons, and pressed wood.

### AIR AT 6 BAR

vacuum in - BAR	0	0.1	0.2	0.3	0.4	0.5	0.6	0.7
time in sec for evacuation of 1 lit to vac' level VLP - 48	-	.0023	.0075	.015	0.03	0.045	0.075	0.13
induced air in lit per min. VLP - 48	3200	2040	1260	780	540	450	300	-

